

Dynamic Fire Damper ▲ 1½ Hour Rated ▲ Curtain Blade ▲ Horizontal and Vertical Mount ▲ Galvanized Steel

STANDARD MATERIALS AND CONSTRUCTION

- FRAME:** 22-GA galvanized steel, one-piece rollformed
- BLADE:** 22-GA galvanized steel, curtain type
- FUSIBLE LINK:** UL-Listed 165°F; Replaceable
- CLOSURE SPRINGS:** Heat-treated Type 301 stainless steel constant force coiled negator type
- FINISH:** Mill

UNDERWRITERS LABORATORIES INC.®
 DYNAMIC CURTAIN FIRE DAMPER
 FIRE RESISTANCE RATING 1½ HR

FILE # R4708

Dampers ▲ Louvers
UL Life Safety Products

OPTIONS

- 212°F Replaceable Fusible Link
- Factory-Supplied Sleeves (20-GA through 10-GA)
- PK1202 Position Indicator Switch
- B-Pan, Round, Oval, or Square Transitions
- Tab-Lock Retaining Angles
- Perimeter Flange
- Pull Ring

NOTES

1. Nominal deductions will be made to the opening size given.

DAMPER SIZES

Horizontal Sizing		2000 fpm, 4 in. w.g.		2000 fpm, 8 in. w.g.		4000 fpm, 4 in. w.g.	
		Min Panel	Max Single Panel	Max Assembly	Max Single Panel	Max Assembly	Max Single Panel
A - Frame	4"W x 4"H	24"W x 24"H	72"W x 36"H	18"W x 36"H	36"W x 36"H	18"W x 36"H	36"W x 36"H
B - Frame	4"W x 3"H (duct) (4"W x 5"H frame)	24"W x 20"H (duct) (24"W x 24"H frame)	72"W x 31"H (duct) (72"W x 36"H frame)	18"W x 31"H (duct) (18"W x 36"H frame)	36"W x 31"H (duct) (36"W x 36"H frame)	18"W x 31"H (duct) (18"W x 36"H frame)	36"W x 31"H (duct) (36"W x 36"H frame)
C - Frame	4"W x 4"H (duct) (6"W x 7"H frame)	22"W x 19"H (duct) (24"W x 24"H frame)	70"W x 30"H (duct) (72"W x 36"H frame)	16"W x 30"H (duct) (18"W x 36"H frame)	34"W x 30"H (duct) (36"W x 36"H frame)	16"W x 30"H (duct) (18"W x 36"H frame)	34"W x 30"H (duct) (36"W x 36"H frame)

Vertical Sizing

Vertical Sizing		2000 fpm, 4 in. wg		4000 fpm, 4 in. wg
		Min Panel	Max Single Panel*	Max Assembly
A - Frame	4"W x 4"H	36"W x 36"H	72"W x 36"H	18"W x 36"H
B - Frame	4"W x 3"H (duct) (4"W x 5"H frame)	36"W x 32"H (duct) (36"W x 36"H frame)	72"W x 32"H (duct) (72"W x 36"H frame)	18"W x 32"H (duct) (18"W x 36"H frame)
C - Frame	4"W x 4"H (duct) (6"W x 7"H frame)	34"W x 31"H (duct) (36"W x 36"H frame)	70"W x 31"H (duct) (72"W x 36"H frame)	16"W x 31"H (duct) (18"W x 36"H frame)

*Dampers greater than 36"W have a maximum single panel size of 18"W.

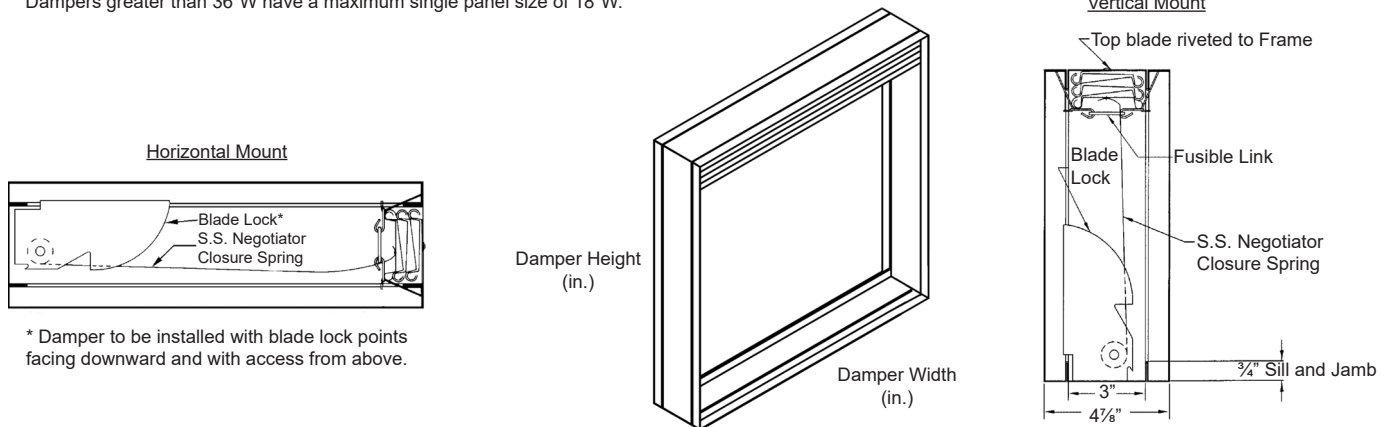

Item #	Qty	Damper Size	Horizontal	Vertical	165°F	212°F						Union Made
			Orientation		Fusible Link							
Arch. / Eng.:					EDR:		ECN:		Job:			
Contractor:												
Project:					Date:		DWN:		DWG:			